



# TRUE FOOD SERVICE EQUIPMENT, INC.

St. Charles Industrial Center • P.O. Box 970 • O'Fallon, Missouri 63366  
(636)240-2400 • FAX (636)272-2408 • (800)325-6152 • www.truemfg.com  
Parts Dept. (800)424-TRUE • Parts Dept. FAX# (636)272-9471

Project Name: \_\_\_\_\_

A/A #

Location: \_\_\_\_\_

Item #: \_\_\_\_\_ Qty: \_\_\_\_\_

SIS #

Model #: \_\_\_\_\_

Model:  
**TRCB-110**

**Chef Base:**  
*Drawered Refrigerator*



## TRCB-110

- ▶ True's refrigerated chef bases are designed with enduring quality that protects your long term investment.
- ▶ Designed using the highest quality materials and components to provide the user with colder product temperatures, lower utility costs, superior food safety and the best value in today's food service marketplace.
- ▶ Oversized, environmentally friendly (134A) forced-air refrigeration system holds 33°F to 38°F (.5°C to 3.3°C).
- ▶ Cabinet top is one piece, heavy duty reinforced 300 series stainless steel. Drip resistant "V" edge protects against spills. Supports up to 2000 lbs. (908 kg).
- ▶ All stainless steel front and cabinet ends. Matching aluminum finished back.
- ▶ Each drawer accommodates two (2) 12"L x 20"W x 4"D (305 mm x 508 mm x 102 mm) food pans (sold separately).
- ▶ Heavy-duty stainless steel drawer slides and rollers. Removable without tools for easy cleaning.
- ▶ Foamed-in-place, high density polyurethane insulation (CFC free).

### ROUGH-IN DATA

Specifications subject to change without notice.  
Chart dimensions rounded up to the nearest 1/8" (millimeters rounded up to next whole number).

Model	Drawers	Cabinet Dimensions (inches) (mm)			HP	Voltage	Amps	NEMA Config.	Cord Length (total ft.) (total m)	Crated Weight (lbs.) (kg)
		L	D†	H*						
TRCB-110	6	100 2540	30 1/2 775	20 1/2 521	1/3	115/60/1	9.5	5-15P	7 2.1	610 277

† Depth does not include 1" (26 mm) for rear bumpers.

\* Height does not include 5" (127 mm) for castors or 6" (153 mm) for optional legs.



#### APPROVALS:

Model:  
**TRCB-110**

**Chef Base:**  
Drawered Refrigerator



## STANDARD FEATURES

### DESIGN

- True's commitment to using the highest quality materials and oversized refrigeration systems provides the user with colder product temperatures, lower utility costs, superior food safety and the best value in today's food service marketplace.

### REFRIGERATION SYSTEM

- Factory engineered, self-contained, capillary tube system using environmentally friendly (CFC free) 134A refrigerant.
- Oversized, factory balanced refrigeration system with guided airflow to provide uniform product temperature.
- Extra large evaporator coil balanced with higher horsepower compressor and large condenser; maintains 33°F to 38°F (.5°C to 3.3°C) for the best in food preservation.
- Sealed, cast iron, self-lubricating evaporator fan motors and larger fan blades give True chef base units a superior low velocity, high volume airflow design. This unique design insures faster temperature recovery and shorter run times in the busiest of food service environments.
- Condensing unit is accessed from behind front grill; slides out for easy maintenance.

### CABINET CONSTRUCTION

- Exterior - stainless steel front, top and cabinet ends. Matching aluminum finished back.

- Interior - attractive, NSF approved, white aluminum liner. 300 series stainless floor with coved corners.
- Insulation - entire cabinet structure and drawers are foamed-in-place using high density, CFC free, polyurethane insulation.
- 4" (102 mm) diameter plate castors - locks provided on front sets.
- Cabinet top is one piece, heavy duty reinforced 300 series stainless steel. Drip resistant "V" edge protects against spills. Supports up to 2000 lbs. (908 kg).

### DRAWERS

- Stainless steel exterior with white aluminum liner to match cabinet interior.
- Heavy-duty stainless steel drawer slides and rollers. Removable without tools for easy cleaning.
- Each drawer fitted with 12" (305 mm) long recessed handle that is foamed-in-place with a sheet metal interlock to insure permanent attachment.
- Magnetic drawer gaskets of one piece construction, removable without tools for ease of cleaning.

### PAN CAPACITY

- Each drawer accommodates (2) full size 12" L x 20" W x 4" D (305 mm x 508 mm x 102 mm) food pans (sold separately).
- Drawers will support a wide variety of incremental pan size configurations; each drawer standard with (1) full length removable divider bar.

### MODEL FEATURES

- Evaporator is epoxy coated to eliminate the potential of corrosion.
- Exterior mounted digital temperature monitor standard.
- NSF-7 compliant for open food product.

### ELECTRICAL

- Unit completely pre-wired at factory and ready for final connection to a 115/60/1 phase - 15 amp dedicated outlet. Cord and plug set included.



115/60/1  
NEMA-5-15R

### RECOMMENDED OPERATION CONDITIONS

- Counter-top cooking equipment should be used in conjunction with the manufacturer supplied legs. Minimum clearance of 4" (102 mm) required between bottom of cooking equipment heating element and the TRCB top. Failure to provide clearance voids manufacturer warranty.

### OPTIONAL FEATURES/ACCESSORIES

Upcharge and lead times may apply.

- 6" (153 mm) standard legs (2 sets of 4 leg mounting plates required).
- 6" (153 mm) seismic/flanged legs (2 sets of 4 leg mounting plates required).
- Heavy duty 16 gauge tops.
- Additional size drawer divider bars.
- Remote cabinets (condensing unit supplied by others), consult factory technical service department for BTU information.

## PLAN VIEW

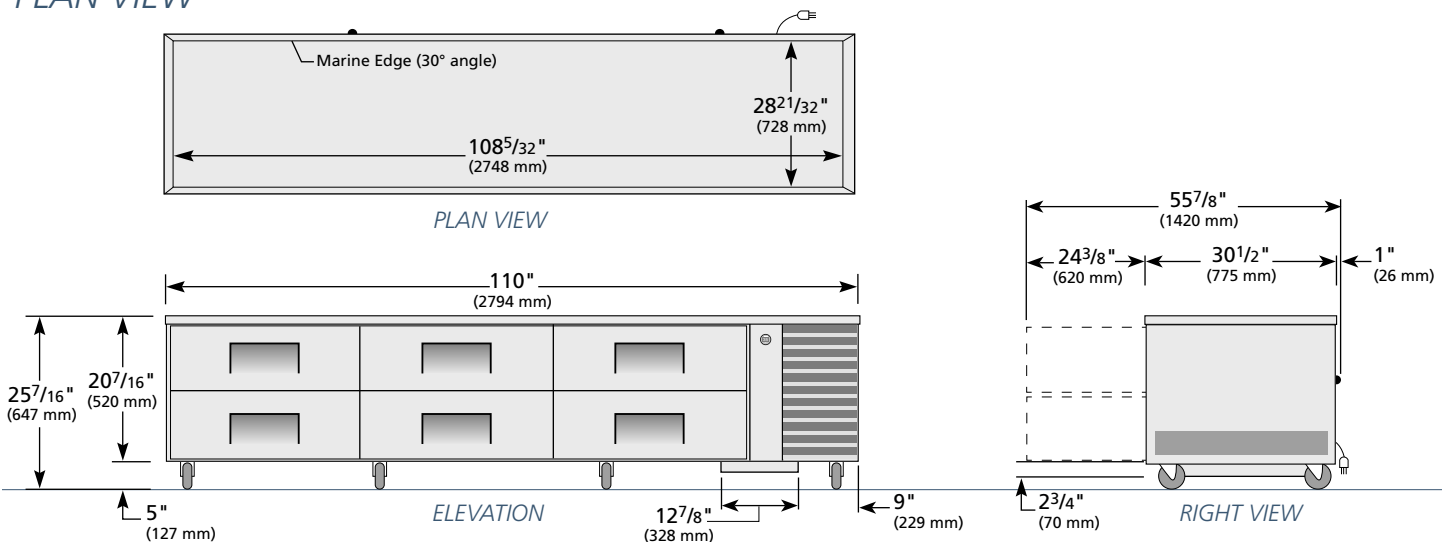

### WARRANTY

One year warranty on all parts & labor and an additional 4 year warranty on compressor. (U.S.A. only)

METRIC DIMENSIONS ROUNDED UP TO THE NEAREST WHOLE MILLIMETER

SPECIFICATIONS SUBJECT TO CHANGE WITHOUT NOTICE



Model	Elevation	Right	Plan	3D
TRCB-110	TFQY137E	TFQY49S	TFQX66P	TFQY137S

## TRUE FOOD SERVICE EQUIPMENT

St. Charles Industrial Center • P.O. Box 970 • O'Fallon, Missouri 63366 • (636)240-2400 • FAX (636)272-2408 • (800)325-6152 • www.truemfg.com