

Project	Quantity	Item #
Model Specified:		CSI Section 11400

## Compact Undercounter Refrigerators/ Self-Contained

### 27", 48" & 60" Wide Models



Stainless Exterior,  
Anodized  
Aluminum Interior

27" Wide One Door Model  
48" Wide Two Door Model  
60" Wide Two Door Model

UHT27  
UHT48  
UHT60



Left To Right Models UHT60, UHT48 & UHT27  
(shown with optional casters)

Finally there is a compact undercounter product worthy of the Traulsen name. Their rugged construction and high quality components make these units capable of standing up to the demanding environment of any foodservice kitchen. Each unit is built with a high quality stainless steel exterior and durable anodized aluminum interior.

They are also designed for high performance, providing accurate temperature maintenance. Fresh, safe food is assured, even under the most demanding conditions.

Their front breathing design allows for "zero-clearance" installation. As a result they can be placed right up against the backwall and alongside other kitchen equipment, saving valuable floor space. Additionally, they offer a wide range of optional accessories to choose from, and are ideal for use with many different type applications.

## Standard Product Features

- Stainless Steel Exterior Top, Sides & Door(s)
- Anodized Aluminum Interior
- Front Breathing Self-Contained Refrigeration System
- Environmentally Friendly R-134a Refrigerant
- Self-Closing Stainless Steel Door(s) With Stay Open Feature At 105 Degrees
- Horizontal Work Flow Door Handle
- Anodized Aluminum Interior Door Liner
- Standard Door Hinging: UHT27 = Left, UHT48 = Left/Right, UHT60 = Left/Right (other hingings available)
- Interior Mounted Thermometer
- Two (2) Powder Coated Shelves Per Door, Mounted On Pilasters
- Automatic Non-Electric Condensate Evaporator
- Magnetic Snap-In Door Gasket(s)
- 8' Cord & Plug Attached
- Set of Four (4) 6" High Adjustable Legs (6 for model UHT60)
- One Year Parts And Labor Warranty
- Five Year Compressor Warranty

## Options & Accessories

- 22 Gauge Stainless Steel Worktop With 4" High Backsplash
- Stainless Steel Finished Back
- Additional Powder Coated Shelves
- 6" Overall Height Casters (for use in lieu of legs)
- 4" Overall Height Casters (for use in lieu of legs)
- 3-1/2" Overall Height Casters (for use in lieu of legs)
- 2-1/2" Overall Height Casters (for use in lieu of legs, 27" models only)
- 4" High Stainless Steel Utility Base (for use in lieu of legs)
- Compact Undercounter Stacking Kit (for use in stacking two 27" units one on top of the other)
- Two Year Service/Labor Warranty Available



Listed by Underwriters Laboratories Inc., to U.S. and Canadian safety standards and Listed by NSF International.

Approval: \_\_\_\_\_



TRAULSEN  
4401 BLUE MOUND RD.  
PHONE 1 (800) 825-8220  
Website: www.traulsen.com

FT. WORTH, TX 76106  
FAX-MKTG. 1 (817) 624-4302

SECTION  
9-1

Project	Quantity	Item #
Model Specified:		CSI Section 11400

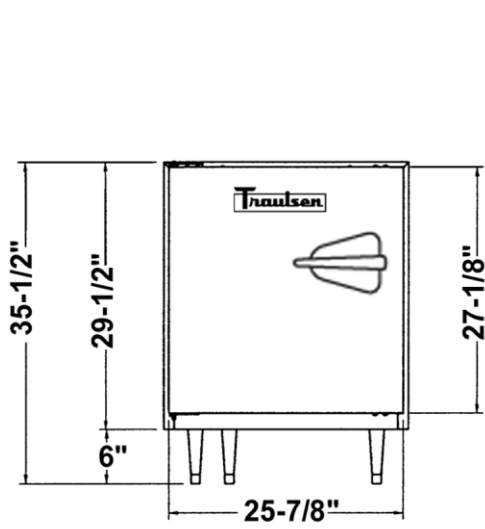

Elevation - UHT27

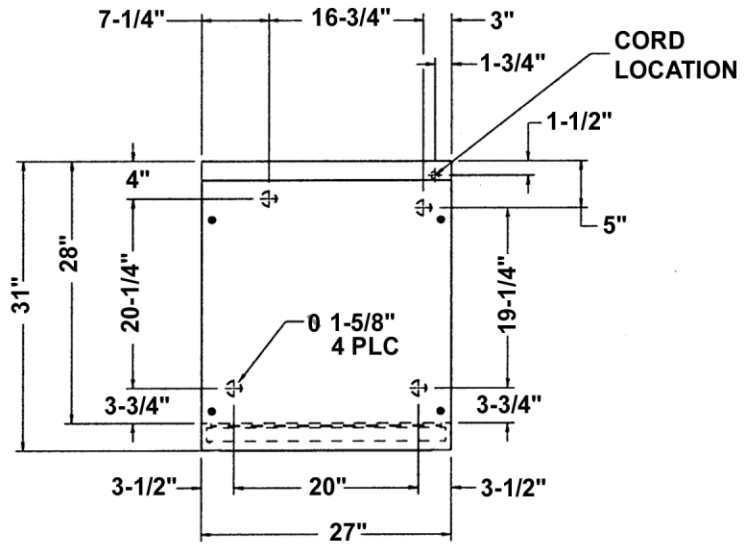

Plan - UHT27

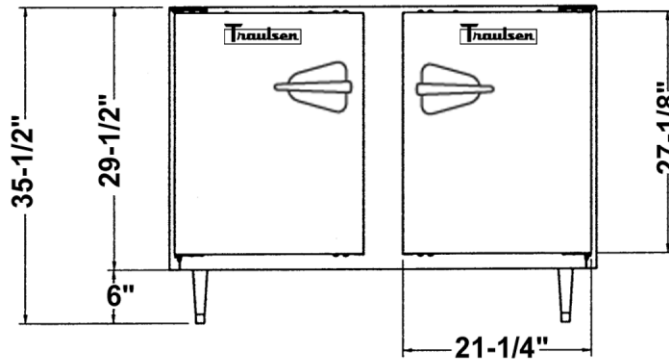

Elevation - UHT48

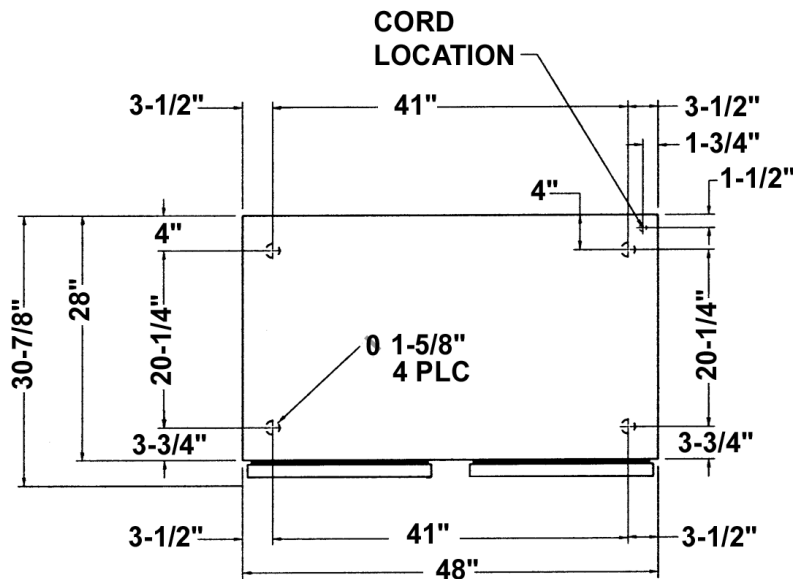

Plan - UHT48

Project	Quantity	Item #
Model Specified:		CSI Section 11400

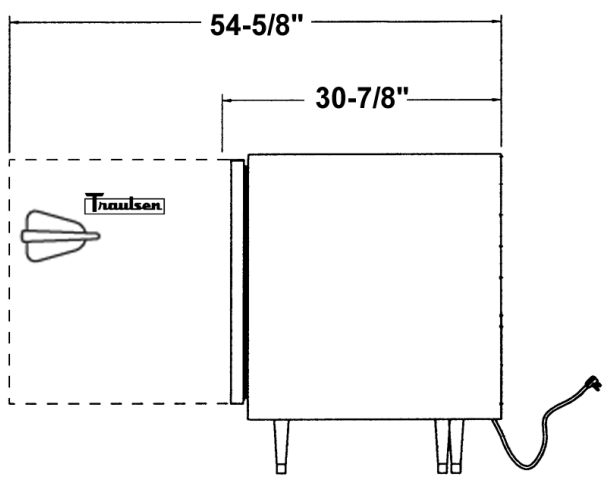

Section - 27" & 60" Models

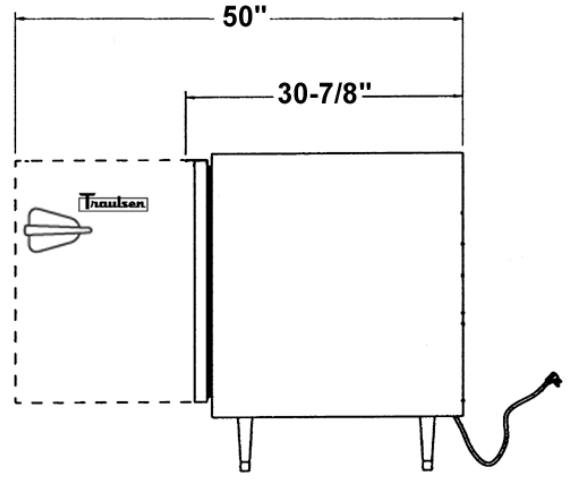

Section - 48" Models

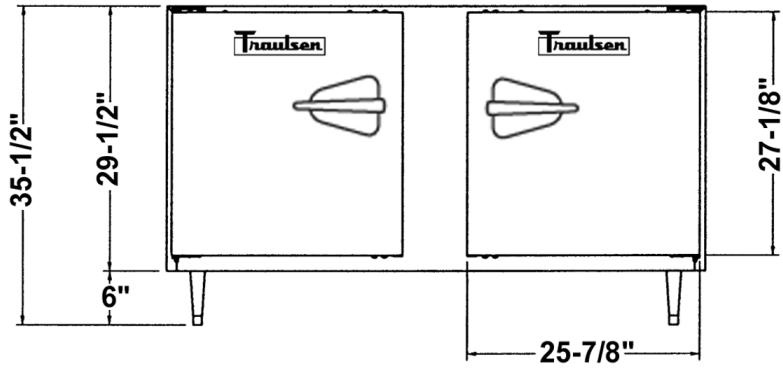

Elevation - UHT60

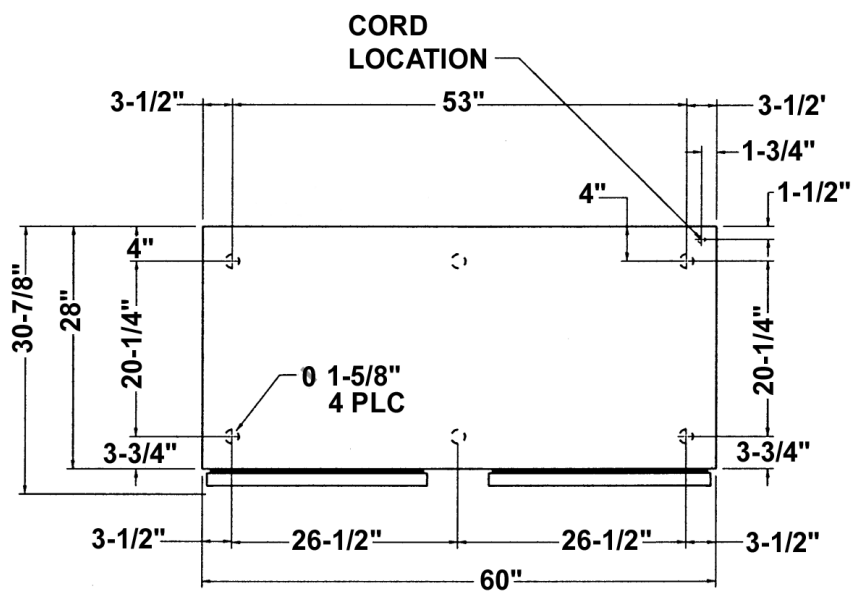

Plan - UHT60



**TRAUlsen**  
 4401 BLUE MOUND RD.  
 PHONE 1 (800) 825-8220  
 Website: www.traulsen.com

FT. WORTH, TX 76106  
 FAX-MKTG. 1 (817) 624-4302

**SECTION**  
 9-1

Project	Quantity	Item #
Model Specified:		CSI Section 11400

## Specifications

### Construction, Hardware and Insulation

Cabinet exterior front, one piece sides, louver assembly and doors are constructed of 22 gauge stainless steel. Cabinet interior and door liners are constructed of anodized aluminum. The exterior cabinet back and bottom are constructed of galvanized steel.

A stainless steel door with a recessed work-flow handle and anodized aluminum liner is provided. The door self closes at less than 90 degrees and also includes a stay open feature at 105 degrees. Easily removable for cleaning, vinyl magnetic door gasket assures tight door seal.

Both the cabinet and door(s) are insulated with an average of 2" thick high density, non-CFC, foamed in place polyurethane.

### Refrigeration System

A balanced, rear mounted, front breathing, self-contained refrigeration system using R-134a refrigerant is provided. It features a capillary tube metering device, air-cooled hermetic compressor, a forced air evaporator coil and a non-electric condensate evaporator. An 8' cord and plug is provided. Standard operating temperature is 34 to 38°F.

### Interior

Standard interior arrangements include two (2) powder coated wire shelves per door, mounted on pilasters. These are adjustable in 1/2" increments, allowing for a minimum of 1-1/2" spacing between shelves.

### Warranties

Both a one year parts and labor warranty and a five year compressor warranty (self-contained models only) are provided standard. An optional 2<sup>nd</sup> year extended parts and labor warranty is also available.

DIMENSIONAL DATA	UHT27	UHT48	UHT60
Net capacity cu. ft.	7.1	13.1	16.7
Length - overall in.	27	48	60
Depth - overall in.	30 <sup>7</sup> / <sub>8</sub>	30 <sup>7</sup> / <sub>8</sub>	30 <sup>7</sup> / <sub>8</sub>
Depth - with door open 90°	54 <sup>3</sup> / <sub>8</sub>	50	54 <sup>3</sup> / <sub>8</sub>
Clear door height in.	24 <sup>1</sup> / <sub>8</sub>	24 <sup>1</sup> / <sub>8</sub>	24 <sup>1</sup> / <sub>8</sub>
Clear door width in.	22 <sup>3</sup> / <sub>4</sub>	18 <sup>1</sup> / <sub>4</sub>	22 <sup>3</sup> / <sub>4</sub>
Height - overall on 6" legs in.	35 <sup>1</sup> / <sub>2</sub>	35 <sup>1</sup> / <sub>2</sub>	35 <sup>1</sup> / <sub>2</sub>
Number of shelves - total	2	4	4
Shelf area sq. ft.	4.88	10.3	13.2
ELECTRICAL DATA			
Voltage	115/60/1	115/60/1	115/60/1
Full Load Amperes	3.3	5.7	5.7
Wattage	225	480	480
REFRIGERATION DATA			
Refrigerant	R-134a	R-134a	R-134a
BTU/HR - H.P. <sup>1</sup>	889 (1/8 HP)	1869 (1/4 HP)	1869 (1/4 HP)
SHIPPING DATA			
Net Wt. lbs.	250	265	355
Gross Wt. lbs.	275	290	380

### NOTES

1= Based on a 90 degree F ambient and 20 degree F evaporator.



**Equipped With One NEMA 5-15 P Plug**

**NOTE: When ordering please specify: Voltage, Hinging, Optional Accessories and any additional warranties.**

Continued product development may necessitate specification changes without notice.  
Part No. TR35819 (revised 4/04)

**NOTE: Freight charges are FOB destination for dock to dock delivery within the continental USA. Liftgate delivery charges are additional. For inside delivery charges, please consult factory.**

**SECTION  
9-1**

**TRAUlsen**  
4401 BLUE MOUND RD.  
PHONE 1 (800) 825-8220  
Website: [www.traulsen.com](http://www.traulsen.com)

**FT. WORTH, TX 76106  
FAX-MKTG. 1 (817) 624-4302**

