



FC16



FC16-2

FC16 Series conveyor ovens

Doyon fast conveyor ovens are your best buy to increase production in less space, bake 30% to 50% faster than traditional ovens, improve product consistency, reduce labor costs and minimize energy costs by 35% to 65%. Predetermine belt speed (cooking time) and temperature, place the food on the moving conveyor belt and remove for perfect results everytime. With a 17 1/4" X 3" (438 mm X 76 mm) opening and an increased production per square foot, Doyon conveyor ovens are not only the strongest of the industry, they are the most attractively priced of their category.

FC16

“Superior *quality* product
at an *affordable* price !”

Countertop conveyor ovens FEATURING

- Compact and stackable
- Jets of high velocity hot air delivered to food
- Faster consistent cooking than traditional, infrared and convection ovens
- Guaranteed even baking
- First in, first out
- Allow inexperienced employees to produce quality products with a minimum of training
- Bake pizzas in 5 to 6 minutes
- Save on labor costs
- Save on energy bills
- 16" (406 mm) wide stainless steel belt with a 17 1/4" (438 mm) opening
- Adjustable speed and temperature
- Better moisture retention
- Low maintenance and easy cleaning
- Shipped fully assembled
- Temperature up to 600°F (300°C)
- Entry and exit shelf included
- Electric model only
- ETL and ETL sanitation listed
- One year parts and labor limited warranty

OPTIONAL

- Extended conveyor: 56" (1420 mm)

DIMENSIONS

FC16	43 1/4"W	X 31 3/4"D	X 18 1/4"H
	(1100 mm)	X (806 mm)	X (464 mm)
FC16-2	43 1/4"W	X 31 3/4"D	X 32 1/2"H
	(1100 mm)	X (806 mm)	X (826 mm)

BAKING CHAMBER DIMENSIONS

23 1/4"W	X 17 1/4"D	X 3 "H
(591 mm)	X (438 mm)	X (76 mm)

ELECTRICAL SYSTEM (per unit)

208V - 1 PH - 29 A - 6.1 kW - 2 wires - 60 Hz NEMA 6-50P
240V - 1 PH - 26 A - 6.1 kW - 2 wires - 60 Hz NEMA 6-50P
220V - 1 PH - 31 A - 6.8 kW - 2 wires - 60 Hz NEMA 6-50P
220V - 1 PH - 31 A - 6.8 kW - 2 wires - 50 Hz

PRODUCTION PER HOUR PER UNIT (500°F/260°C - 5 min)

16 - 16" (406 mm) Pizzas
40 - 9" (229 mm) Pizzas
90 - 6" (152 mm) Pizzas

SHIPPING WEIGHT

335 lbs per unit (152 kg) approximately

Specifications and design subject to change without notice.

FC16

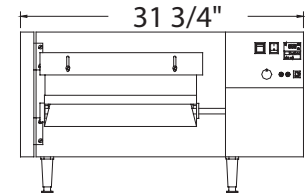
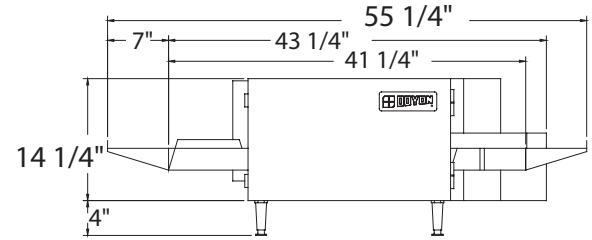

TOP VIEW

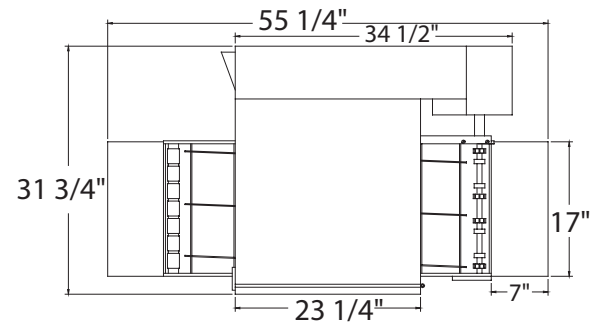

FC16 - 2

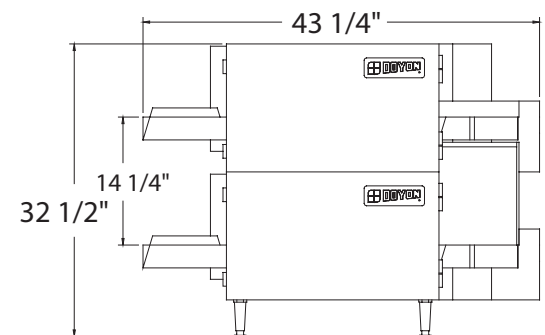

1255, rue Principale
Linière, Beauce, Québec, Canada G0M 1J0

Telephone.: 418-685-3431
Canada: 1-800-463-1636
E-mail : doyon@doyon.qc.ca

Fax: 418-685-3948
U.S.: 1-800-463-4273
Internet : <http://www.doyon.qc.ca>



Your local distributor: / Votre distributeur:

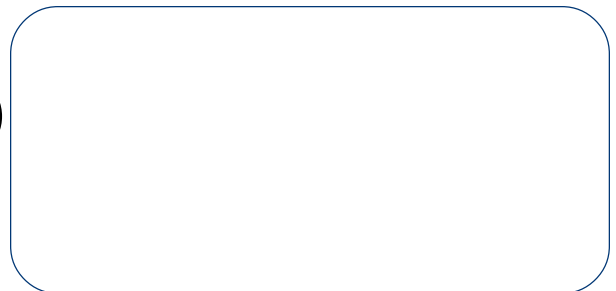

Printed in Canada Rev. 092003a