



Item # \_\_\_\_\_

# Model E-222 Meat Grinder



Meat Grinder Model E-222



Model E-222



## Safety and Convenience Features

Berkel Model E-222 meat grinder is a high performance, versatile machine. Its compact design, with an increased output height allows for a wide range of receiving containers for finished product. The unit's grinding body is separated from the motor to prevent heat transfer to the product. This feature, combined with a short feed screw, helps to produce less heat, which increases the overall shelf life of ground products and improves the quality of grind without the loss of product color. The E-222 has a dependable, oil-filled gearbox assembly with hardened gears to assure quiet operation and years of service under normal conditions. A non-removable top cover and tray safety guard are standard. The output housing removes easily without tools to facilitate cleaning.

## Standard Features

- ▶ Short feed screw helps to produce less heat, which increases the overall shelf life of ground products; quality of grind is improved without the loss of product color
- ▶ Large stainless steel tray holds more product increasing productivity
- ▶ 1-speed, 1 HP, totally enclosed and permanently lubricated motor, thermally protected
- ▶ Furnished in 115/60/1, 13.6 amp, AC, ETL listed; also available in 220/60/1, 6.8 amp, AC, ETL listed
- ▶ Dependable, oil-filled gearbox assembly with hardened gears assures quiet operation
- ▶ Grinding body is separated from the motor to prevent heat transfer to the product; removes and disassembles easily without tools to facilitate cleaning
- ▶ 1/8" (3 mm) and 3/16" (5 mm) alloy steel plate is standard; optional 1/4" (6 mm), and 3/8" (9.5 mm) plates are also available
- ▶ Capacity of up to 20 lbs. (9 kg.) per minute; feed screw speed of 235 RPM
- ▶ Highly reliable, moisture resistant, on/off toggle switch with safety guard and power indicator light
- ▶ Housing and product tray are stainless steel, feed screw is hot tin dipped; unit disassembles quickly without tools for easy cleaning
- ▶ Attached 6-foot, flexible, 3-wire cord and plug for grounded receptacle

## Option

- 220/60/1, 6.8 amp, AC, ETL listed

## Accessories

- 1/8" (3 mm) alloy steel plate
- 3/16" (5 mm) alloy steel plate
- 1/4" (6 mm) alloy steel plate
- 3/8" (9.5 mm) alloy steel plate knife

|                                  |
|----------------------------------|
| Approved By: _____<br>Date _____ |
|----------------------------------|

Berkel Company • 4406 Technology Drive • South Bend, IN 46628-9700  
574-232-8222 • 800-348-0251 • FAX 888-888-2838 • www.berkel.com

**Berkel**

# Model E-222

## Meat Grinder

| Model No. | Output Capacity        | Product Dimensions |                  |                   |
|-----------|------------------------|--------------------|------------------|-------------------|
|           |                        | Width A            | Depth B          | Height C          |
| E-222     | 20 lbs. (9 kg.)/minute | 15-1/2" (394 mm)   | 28-5/8" (727 mm) | 18-9/16" (471 mm) |

| Motor           | Electrical | Weight                                       | Feed Screw RPM | Box Dimensions  |                 |                 |
|-----------------|------------|--|----------------|-----------------|-----------------|-----------------|
|                 |            |  |                | Width           | Depth           | Height          |
| 1-speed<br>1 HP | 115/60/1   | Net 96 lbs. (44 kg)<br>Ship 106 lbs. (49 kg) | 235            | 18"<br>(457 mm) | 31"<br>(787 mm) | 20"<br>(508 mm) |

### Specifications

**Design:** Compact design, with an increased output height allows for a wide range of receiving containers. The large stainless steel tray 15-1/2" (394 mm) W x 3" (76 mm) D x 26-1/2" (673 mm) holds more product increasing productivity.

**Standard Features:** Stainless steel product tray, burnadized aluminum rammer, alloy steel plates with 1/8" (3 mm) and 3/16" (5 mm) holes, two hardened steel cutting knives and protective tray guard to keep hands from feed screw are standard.

**Grinding Housing:** Grinding body is separated from the motor to prevent heat transfer to the product and removes and disassembles easily without tools to facilitate cleaning. The short feed screw helps to produce less heat, which increases the overall shelf life of ground products; quality of grind is improved without the loss of product color. Includes #22 size 3-1/4" (82 mm) diameter head; 1/8" (3 mm) and 3/16" (5 mm) alloy steel plates as standard. Optional 1/4" (6 mm), 3/8" (9.5 mm) plates are also available.

**Motor:** 1-speed, 1 HP, totally enclosed, permanently lubricated ball bearings, thermally protected.

**Electrical:** Furnished in 115/60/1, 13.6 amp, AC, ETL listed. Also available in 220/60/1, 6.8 amp, AC, ETL listed.

**Finish/construction:** Housing and product tray are stainless steel; feed screw is hot-tin dipped. The unit disassembles quickly without tools for easy cleaning.

**Transmission:** Dependable, oil-filled gearbox assembly with hardened gears assures quiet operation.

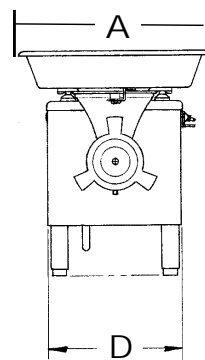
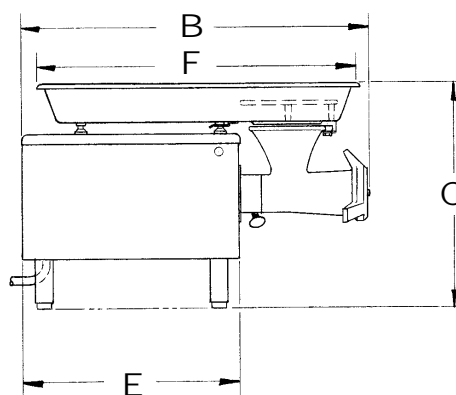

- A: 15-1/2" (394 mm)
- B: 28-5/8" (727 mm)
- C: 18-9/16" (471 mm)
- D: 11" (279 mm)
- E: 17-7/8" (454 mm)
- F: 26-1/2" (673 mm)

**Switch:** Highly reliable, moisture resistant, on/off toggle switch with safety guard.

**Cord and Plug:** Attached 6-foot, flexible, 3-wire cord and plug for grounded receptacle.

**Warranty:** All parts, service and travel coverage for one year, excluding wear items.

As we continually strive to improve our products, specifications are necessarily subject to change without notice.

Berkel Company • 4406 Technology Drive • South Bend, IN 46628-9700  
574-232-8222 • 800-348-0251 • FAX 888-888-2838 • [www.berkel.com](http://www.berkel.com)