

**ANVIL**

VACK PACK MACHINES

IN CHAMBER



VACK PACK MACHINE

"Anvils Vacuum packing machines extend the shelf life of perishable food products by removing the air that surrounds the product, thereby preventing the growth of bacteria and mould.."

APPLICATION

- SUITABLE FOR USE WITH WET OR DRY PRODUCTS
- EXTENDS REFRIDGERATED SHELF LIFE
- REDUCES FOOD WASTE
- PREVENTS THE TRANSFER OF FLAVORS AND AROMAS WHEN STORING FOOD

CONSTRUCTION

- STAINLESS STEEL CONSTRUCTION
- SAFETY AND HYGIENE MEET THE NEEDS OF DEMANDING CUSTOMERS WORLDWIDE



Anvil reserves the right, without notice, to make changes and revisions to product specifications, materials and design, which in our opinion, will provide better performance, durability and efficiency.

QUALITY  GUARANTEE

ALL ANVIL EQUIPMENT COMES WITH A ONE YEAR WARRANTY ON COMPONENTS AND DEFECTIVE WORKMANSHIP.



NOTE:

When viewing the appliance from the front in its usual operating position, the width (W) of the product is the total distance from left to right ; the depth (D) of the product is the total distance from front to back ; the height (H) is the total distance from the bottom of the product to the top

VACK PACK MACHINE MODELS:
VMA7012
VMA7018

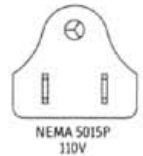
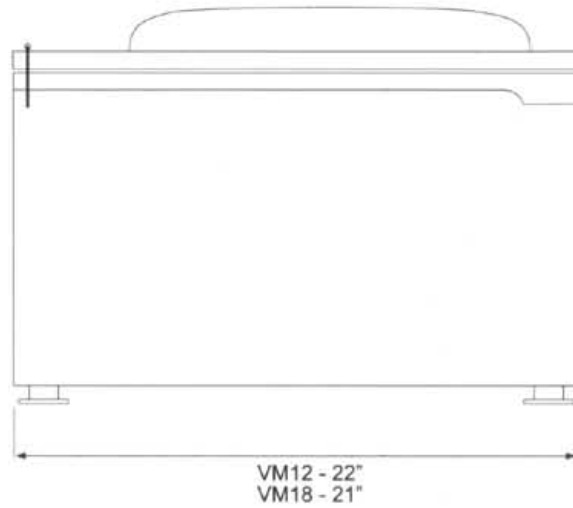
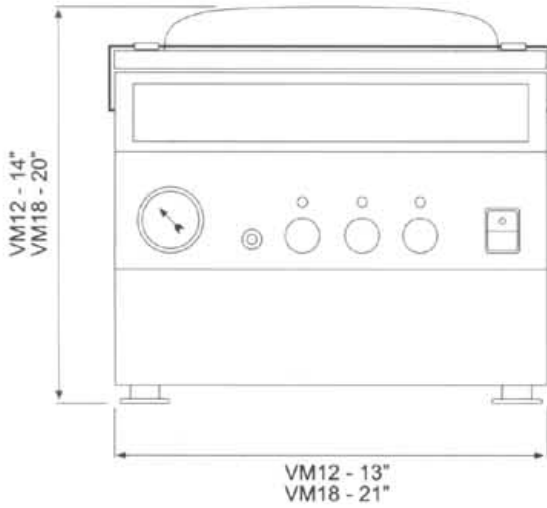

DESCRIPTION	VACK PACK - 12	VACK PACK - 18	ACCESSORIES
MODELS	VMA7012	VMA7018	VBA0812 - 8 x 12" BAG
CHAMBER SIZE (in)	11 x 16 x 5	17 x 17 x 19	VBA1014 - 10 x 14" BAG
SEALING BAR LENGTH (in)	10	16	VBA1212 - 12 x 16" BAG
VOLTAGE (V)	110	110	VBA1418 - 14 x 18" BAG
DIMENSIONS (in) (W x D x H)	13 x 22 x 14	21 x 21 x 20	
BOX DIMNS (in) (W x D x H)	17 x 25 x 18	25 x 25 x 24	

Note: Output performance figures quoted are dependant on various factors.

Manufactured by:
Scientific Engineering (Pty) Ltd
South Africa
Website: www.anvilworld.com



VMA_ANVIL_USA_01